

МОСТИ ТА ТУНЕЛІ: ТЕОРІЯ, ДОСЛІДЖЕННЯ, ПРАКТИКА

УДК 624.21:624.131.042-047.44

A. V. RADKEVYCH¹, O. I. DUBINCHYK^{2*}, ZUOLIN HU³, B. YU. KOZAK⁴

¹Architectural Engineering Institute, Zhejiang Guangsha Vocational and Technical University of Construction, Dongyang, Zhejiang, People's Republic of China, 322100, tel. +86-0579-86668872, email a.v.radkevich@ust.edu.ua, ORCID 0000-0001-6325-8517

^{2*}Department «Transport Infrastructure», Ukrainian State University of Science and Technologies, Lazariana St., 2, Dnipro, Ukraine, 49010, tel. +38 (095) 582 14 88, e-mail o.i.dubinchyk@ust.edu.ua, ORCID 0000-0003-4059-2357

³Architectural Engineering Institute, Zhejiang Guangsha Vocational and Technical University of Construction, Dongyang, Zhejiang, People's Republic of China, 322100, tel. +86-0579-86668872, email 20191756@zjgsdx.edu.cn, ORCID 0009-0003-3417-8835

⁴Department of Military Training of Specialists of the State Special Service of Transport, Ukrainian State University of Science and Technologies, Lazariana St., 2, Dnipro, Ukraine, 49010, tel. +38 (063) 191 14 09, email b.y.bogdan@ust.edu.ua, ORCID 0009-0003-5845-9797

ANALYSIS OF MODES AND FREQUENCIES OF NATURAL VIBRATIONS AND DYNAMIC STRESSES OF BRIDGE ABUTMENT FOUNDATION AND SOIL BASE

Purpose. The purpose of the research work is to determine, during the modal analysis, the modes and frequencies of natural vibrations of the railway bridge abutment together with the pile cap and pile foundation. A separate task of the research is to clarify the dynamic influence of the abutment structure on the possibility of vibrational displacements of the soil base. **Methodology.** To calculate the pile foundation of the abutment, which interacts with the surrounding massif, it was decided to use the finite element method (FEM) based on Structure CAD for Windows, version 7.31 R.4 (SCAD). To reproduce the features of the pile foundation of the abutment, a flat (quasi-spatial) model was used in the research. All dimensions of the pile cap and piles are adopted according to the design documentation for the construction of an actual overpass. **Findings.** An analysis of the stress-strain state results of the overpass abutment foundations, taking into account the train load, was performed, which made it possible to obtain a conclusion about the high bearing capacity of all parts of the “pile – pile cap” system for all considered types of load combinations with a safety margin of 8 and 7 times, respectively, which indicates normal operation in the future provided an unchanged state of engineering and geological conditions and loads. The pile material, class C30/35 concrete, fully withstands all types of loads represented by load combinations, taking into account the dynamic coefficient. The modal analysis of the overpass abutment foundations shows that the obtained frequencies and modes for the foundation are equal to 2.5 Hz (fundamental tone) ... 6.6 Hz, and from comparing these frequencies with the liquefaction frequencies of wet sands (30 ... 50 Hz) it is clear that the support's own vibrations cannot cause vibration-induced liquefaction. **Originality.** The originality of the conducted research lies in obtaining the parameters of dynamic displacements and natural vibration frequencies during the modal analysis of a railway bridge abutment. **Practical value.** The practical value lies in substantiating the strength of the abutment structure under varying load combinations, as well as in determining that the dynamic impact of the rolling stock does not affect the vibrational displacements of the foundation soils.

Keywords: bridge abutment foundation; modes and frequencies; natural vibrations; dynamic stresses; soil base

Introduction

A specific feature of the transport structures operation is their response to dynamic actions from moving traffic. Such actions, together with the variety of locations of their application to the transport structure, significantly complicate the calculations of the stress-strain state of its foundation (Rashidi, Zhang, C. Ghodrat, Kempton, Sama-

li, et al., 2018; Wu, Jiang, & Liu, 2020).

Most often, for these transport structures in the form of overpasses of various types, the structure is that part of the system that receives the vibrations from a moving source, which is in many cases a railway rolling stock. It should be noted that the complexity of the structures and soil foundations behavior under dynamic loads is significantly higher than under static ones.

МОСТИ ТА ТУНЕЛІ: ТЕОРІЯ, ДОСЛІДЖЕННЯ, ПРАКТИКА

The main drawback of the modern approach to studying the behavior of a structure and foundation is limited information about the behavior of the soil base while having a sufficient volume of information about the structure itself. The features of this approach give more accurate results in determining the dynamic characteristics of the structure, but insufficient knowledge of the deformed state under dynamic impact on transport structures leads to negative consequences in their design.

Solving problems of structures and soils dynamics using FEM opens up new possibilities for the analysis of the system “pile foundation of a bridge support – soil base” (Li, Zhou, Chan, & Yu, 2007; Whelan, Gangone, Janoyan, & Jha, 2009; Wymysłowski, & Kurałowicz, 2016; Deng, Ge, & Lei, 2023). A sufficiently theoretically developed FEM dynamic problem allows for modal analysis (determination of the characteristics of natural vibrations) and analysis of dynamic parameters during forced vibrations.

Therefore, the information about the behavior of the structure obtained using FEM is the most complete (Ellis, & Springman, 2001). The main disadvantage of using FEM in the analysis of dynamic characteristics and parameters of the SSS for “pile foundation of a bridge support – soil base” system is the lack of sufficient theoretical substantiation of the combined behavior of both its parts under the action of dynamic loading. However, this disadvantage is inherent rather not to the theoretical foundations of FEM, but to the possibilities of interpreting the soil base and its behavior under the action of dynamic loading.

Purpose

The purpose of the research work is to determine, during the modal analysis, the modes and frequencies of natural vibrations of the railway bridge abutment together with the pile cap and pile foundation. A separate task of the re-search is to clarify the dynamic influence of the abutment structure on the possibility of vibrational displacements of the soil base.

Methodology

The main structural elements of the pile foundation are piles (ДБН В.1.2-2:2006, 2006; ДБН В.2.1-10-2009, 2009). In this case, the pile foundation of the overpass is constructed on bored piles

(Fig. 1 and 2). The foundation is constructed with a pile cap buried in the sand. The number of piles in the foundation is 12 pieces.

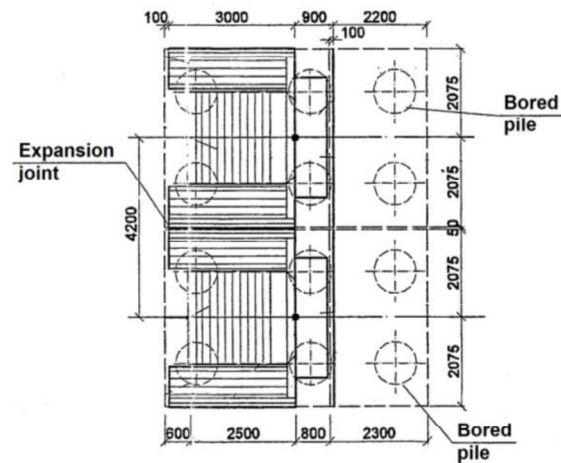

Fig 1. View of the abutment from above

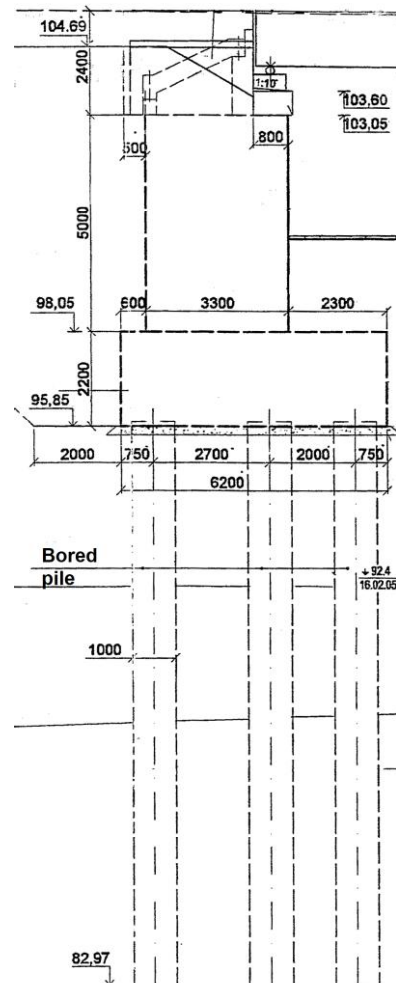

Fig. 2. General view of the abutment

The pile reinforcement consists of several separate reinforcing frames. Concrete of class C25/30 is used for concreting the piles. The total length of the pile under study is 12.0 m. The distance between the rows of piles is 2.2 m. The piles are embedded into the pile cap by 0.1 m. To ensure the embedment of piles, their upper ends are demolished, the reinforcement is exposed and extended 1 m into the concrete of the pile cap.

The piles are connected by a pile cap, which ensures the coupled operation of the piles. The dimensions of the pile cap are as follows: length – 6.2 m, width – 8.3 m, height – 2.2 m. The connec-

tion between the pile cap and the pier body is achieved by means of reinforcing bar dowels located on the top of the pile cap. The length of the outlets is 1 m.

To calculate the pile foundation of the abutment, which interacts with the surrounding massif, it was decided to use the finite element method (FEM) based on Structure CAD for Windows (Карпиловский, Криксунов, Перельмутер, & al., 2000), version 7.31 R.4 (SCAD) (Fig. 3) (Dubinchyk, Bannikov, Kildieiev, & Kharchenko, 2020; Дубінчик, & Недужа, 2021).

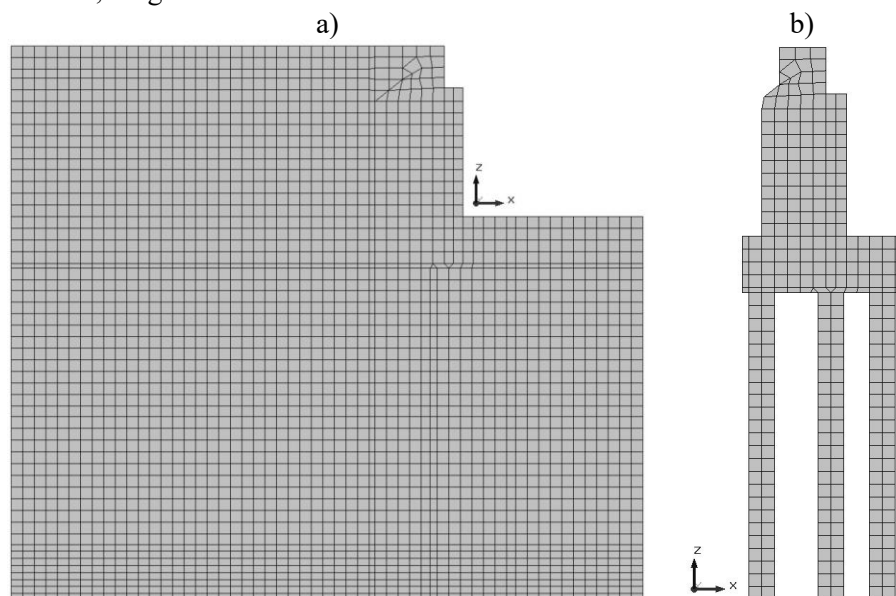

Fig. 3. General view of the model (a) and a fragment of the model (abutment) (b)

To reproduce the features of the abutment's pile foundation, a planar (quasi-spatial) model was used in the research, since the creation of a spatial model of this type of abutment for SCAD is significantly more difficult. This is explained by the complex configuration of the abutment, which, together with the difficult process of modeling circular outlines for piles, presents too great of a difficulty. But the FEM solution using flat elements is an accurate solution to the theory of elasticity, which was presented in fundamental works by many researchers (Stewart, Jewell, & Randolph, 1993; Lu, Xie, & Shao, 2012).

All dimensions of the pile cap and piles are adopted according to the design documentation for the construction of a real overpass. The height of the model is taken from considerations of the joint operation of the piles and the surrounding massif,

which is composed of wet sands of different fractions of high compressibility.

The values of the loads in the combinations for which the abutment and its pile foundation are verified are as follows:

Combination 1 – the self-weight of the FE model with the mass of one span structure, which rests on the abutment (the mass of one 11.5 m long span structure is 22.2 tons, half of the mass is applied to the abutment and, thus, the vertical component is 108.8 kN);

Combination 2 – the first combination with the addition of the mass of the train, which has not yet entered the abutment with one axle at a distance of 0.5 m;

Combination 3 – the first combination with the addition of the mass of the train, which has already entered the abutment with one axle.

The number of finite elements is 5 430, of nodes – 8 457 (the number of degrees of freedom is close to 25 000, considering the restraints). The problem is considered a problem of medium dimension. Based on the above data, calculations of the pile foundation for three load combinations were performed.

Findings

After the calculations were performed, an analysis of the displacements and stresses of the abutment foundation was carried out. Fig. 4 shows the main parameters of the stress-strain state of the overpass support foundation by the combinations. Most of the results are not presented to save space, but their analysis is carried out in the text below.

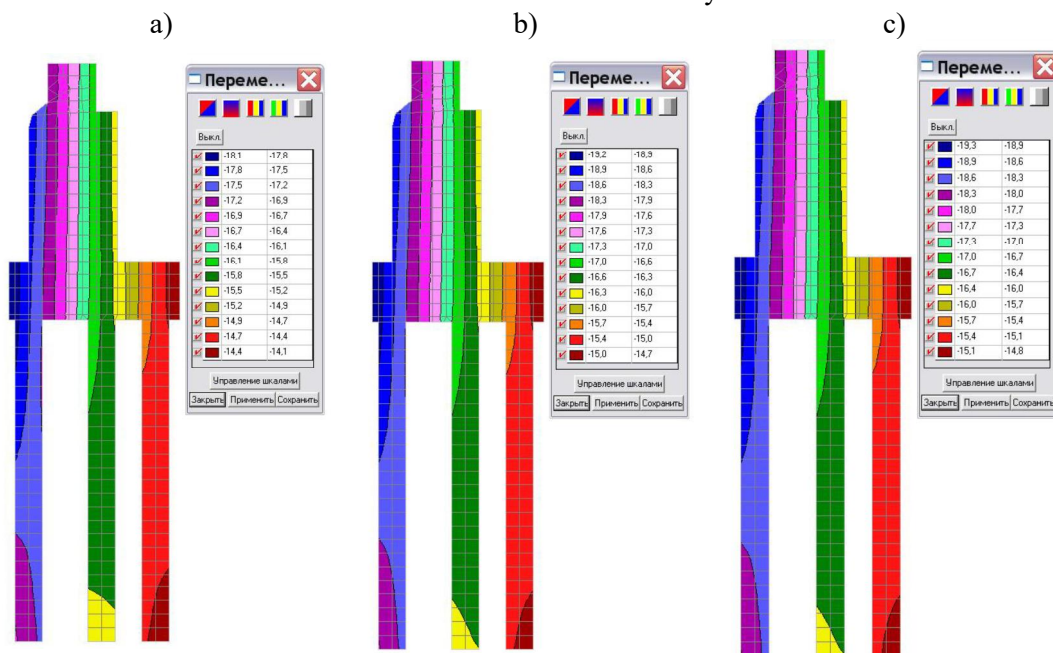

Fig. 4. Isolines and isofields of vertical displacements in a fragment of the abutment model:
a) 1st combination; b) 2nd combination; c) 3rd combination

Analyzing the displacements of the abutment by the combinations, it should be noted that their values are small (horizontal displacements – 5.7 ... 6.0 mm, vertical displacements – 18.1 ... 19.4 mm), and the addition of the train weight is mostly reflected in the vertical displacements, the values of which increase by up to 1 mm.

The most stressed elements of the pile foundation are the pile cap and piles, and the concentration of normal vertical stresses naturally occurs in the lower part of the pile. Having analyzed the values of all the above mentioned components, it should be noted that component analysis is sufficient without calculating equivalent stresses, since the maximum stresses (vertical) are 1.39 ... 2.53 MPa, which, compared with the calculated compressive strength R_b ($R_b=[\sigma]=21$ MPa for class C30/35 concrete pile), allows to indicate a safety margin of 8 times.

The stress state for the three combinations

changes slightly: for combination 1, the values of the maximum stresses (vertical) are 1.6...2.1 MPa (safety margin – 10 times); for combinations 2 and 3, the values of the maximum stresses (vertical) are 1.9...2.53 MPa (safety margin – 8 times). Thus, the pile material, concrete of C30/35 class, fully withstands all types of loads presented by the three combinations. The stress state in the pile cap is similar to the stress state of the piles.

The conclusion to the numerical analysis indicates the appropriate bearing capacity of all parts of the foundation for all considered types of combinations with the appropriate safety margin, which indicates normal operation in the future provided unchanged engineering and geological conditions and loads.

Let's conduct a modal analysis of the finite element scheme and convert the static load from the train into a dynamic one using the dynamic coefficient $\mu=1.25$.

Fig. 5 shows four modes and their corresponding natural frequencies of abutment vibrations with the fundamental tone (1st mode) – 2.5 Hz. Fig. 6

shows the selected parameters of the deformed state taking into account the dynamic coefficient for the combinations.

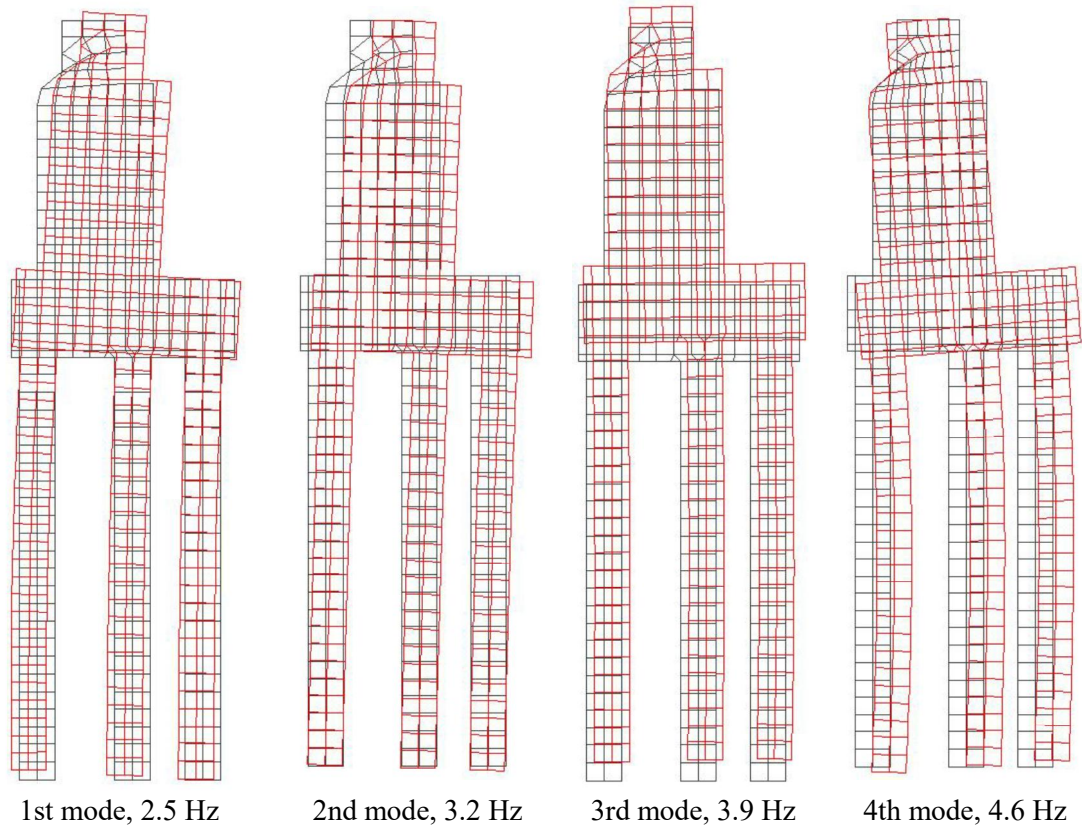

Fig. 5. Modes and frequencies of natural vibrations of an abutment

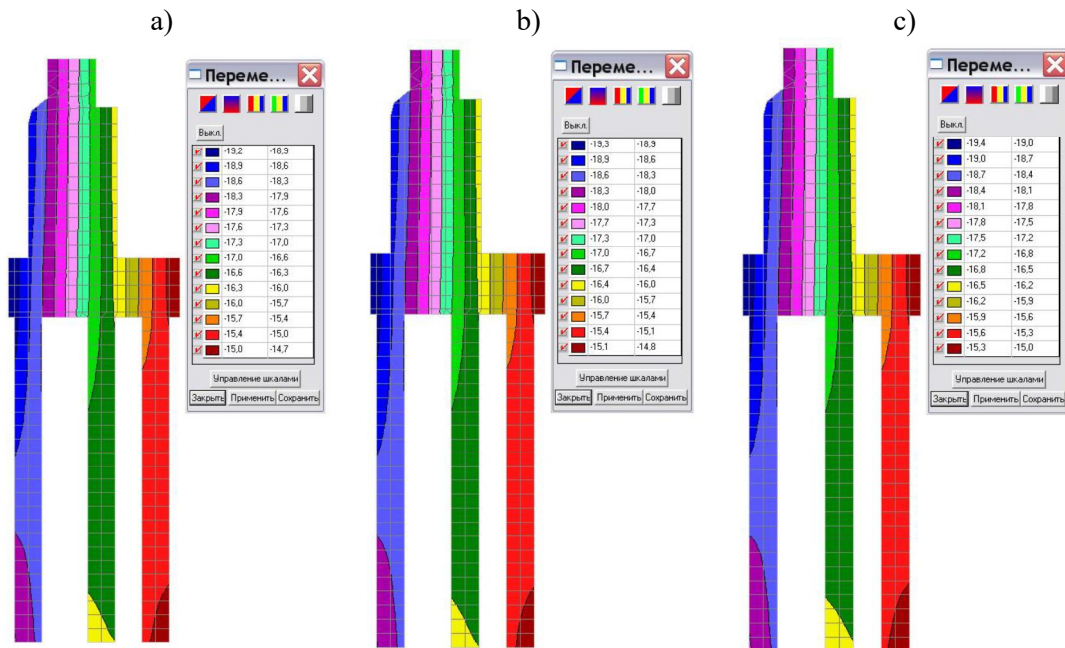

Fig. 6. Isolines and isofields of vertical dynamic displacements in a fragment of the abutment model:
 a) 1st combination; b) 2nd combination; c) 3rd combination

The values of the foundation frequencies for the first eight forms are in the range from 2.5 to 6.8, which indicates that compared with the frequencies of liquefaction of the foundation soils, they are much smaller, and liquefaction will not occur. The only phenomenon that can cause resonance in the abutment structure and destroy it is an earthquake with a low-frequency impact (up to 10 Hz).

Analyzing the dynamic displacements of the foundation from the combinations, it should be noted that their values differ slightly from the static ones (vertical static displacements – 19.2 mm; dynamic one – 19.4 mm), which indicates a slight influence of the dynamic component.

The pile cap (horizontal stresses) and piles (vertical stresses) remain the most stressed elements of the pile foundation, and it should be noted that dynamic stresses, compared to the static ones, have increased by approximately 1.1 times: for combinations 2 and 3, the values of maximum dynamic stresses (vertical) are 2.1 ... 2.6 (static ones were 1.9 ... 2.53 MPa, the safety margin did not change – 8 times). Thus, the pile material, C30/35 class concrete, fully withstands all types of loads presented by combinations, taking into account the dynamic coefficient.

Originality and practical value

The originality of the conducted research lies in obtaining the parameters of dynamic displacements and natural vibration frequencies during the modal analysis of a railway bridge abutment. The practical value lies in substantiating the strength of the abutment structure under varying load combinations, as well as in determining that the dynamic impact of the rolling stock does not affect the vibrational displacements of the foundation soils.

Conclusions

An analysis of the stress-strain state results of the overpass abutment foundations, taking into account the train load, was performed, which made it possible to obtain a conclusion about the high bearing capacity of all parts of the “pile – pile cap” system for all considered types of load combinations with a safety margin of 8 and 7 times, respectively, which indicates normal operation in the future provided an unchanged state of engineering and geological conditions and loads.

The modal analysis of the overpass abutment foundations shows that the obtained frequencies and modes for the foundation are equal to 2.5 Hz (fundamental tone) ... 6.6 Hz, and from comparing these frequencies with the liquefaction frequencies of wet sands (30 ... 50 Hz) it is clear that the abutment's own vibrations cannot cause vibration liquefaction.

REFERENCES

- Ellis, E. A., & Springman, S. M. (2001). Modelling of soil–structure interaction for a piled bridge abutment in plane strain FEM analyses. *Computers and Geotechnics*, 28(2), 79-98. DOI: [https://doi.org/10.1016/S0266-352X\(00\)00025-2](https://doi.org/10.1016/S0266-352X(00)00025-2)
- Deng, Y., Ge, S., & Lei, F. (2023). Effects of pounding and abutment behavior on seismic response of multi-span bridge considering abutment-soil-foundation-structure interactions. *Buildings*, 13(1), 260. DOI: <https://doi.org/10.3390/buildings13010260>
- Dubinchyk, O., Bannikov, D., Kildiev, V., & Kharchenko, V. (2020). Geotechnical analysis of optimal parameters for foundations interacting with loess area. *E3S Web of Conferences, II International Conference Essays of Mining Science and Practice*, 168, 00024. DOI: <https://doi.org/10.1051/e3sconf/202016800024>
- Li, Z. X., Zhou, T. Q., Chan, T. H. T., & Yu, Y. (2007). Multi-scale numerical analysis on dynamic response and local damage in long-span bridges. *Engineering Structures*, 29(7), 1507-1524. DOI: <https://doi.org/10.1016/j.engstruct.2006.08.004>
- Lu, P., Xie, X., & Shao, C. (2012). Experimental study and numerical analysis of a composite bridge structure. *Construction and Building Materials*, 30, 695-705. DOI: <https://doi.org/10.1016/j.conbuildmat.2011.11.008>
- Rashidi, M., Zhang, C., Ghodrati, M., Kempton, S., Samali, B., et al. (2018). Bridge abutment movement and approach settlement – A case study and scenario analysis. *International Journal of Structural Stability and Dynamics*, 18(08), 1840011. DOI: <https://doi.org/10.1142/S0219455418400114>
- Stewart, D. P., Jewell, R. J., & Randolph, M. F. (1993). Numerical modelling of piled bridge abutments on soft ground. *Computers and Geotechnics*, 15(1), 21-46. DOI: [https://doi.org/10.1016/0266-352X\(93\)90015-Y](https://doi.org/10.1016/0266-352X(93)90015-Y)
- Whelan, M. J., Gangone, M. V., Janoyan, K. D., & Jha, R. (2009). Real-time wireless vibration monitoring for operational modal analysis of an integral abutment highway bridge. *Engineering Structures*, 31(10), 2224-2235. DOI: <https://doi.org/10.1016/j.engstruct.2009.03.022>

- Wu, L., Jiang, G., & Liu, X. (2020). Analytical and Numerical Analysis of Additional Stress in Foundation of Bridge Approach Embankment. *Geotechnical and Geological Engineering*, 38, 6069-6082. DOI: <https://doi.org/10.1007/s10706-020-01414-2>
- Wymysłowski, M., & Kurałowicz, Z. (2016). Study of displacements of a bridge abutment using FEM. *Studia Geotechnica et Mechanica*, 38(2), 61-70. DOI: <https://doi.org/10.1515/sgem-2016-0020>
- Дубінчик, О. І., & Недужа, Л. О. (2021). Обґрунтування напружено-деформованого стану пальового фундаменту з використанням програмних комплексів. *Мости та тунелі: теорія, дослідження, практика*, 20, 13-18. DOI: <https://doi.org/10.15802/bttrp2021/245247>
- ДБН В.2.1-10-2009 (2009). *Основи та фундаменти споруд. Основні положення проєктування*. Київ: Мінрегіонбуд України.
- ДБН В.1.2-2:2006 (2006). *Навантаження і впливи. Норми проєктування*. Київ: Мінбуд України.
- Карпиловский, В. С., Криксунов, Э. З., Перельмутер, А. В., & al. (2000). *SCAD для пользователя*. Киев: ВВП «Компас».

А. В. РАДКЕВИЧ¹, О. І. ДУБІНЧИК^{2*}, ЦЗУОЛІНЬ ХУ³, Б. Ю. КОЗАК⁴

¹Інженерно-архітектурний інститут, Професійно-технічний університет будівництва Чжецзян Гуаньша, Дун'ян, Чжецзян, Китайська народна республіка, 322100, тел. +86-0579-86668872, ел. пошта a.v.radkevich@ust.edu.ua, ORCID 0000-0001-6325-8517

^{2*}Кафедра «Транспортна інфраструктура», Український державний університет науки і технологій, вул. Лазаряна, 2, Дніпро, Україна, 49010, тел. +38 (095) 582 14 88, ел. пошта o.i.dubinchyk@ust.edu.ua, ORCID 0000-0003-4059-2357

³Інженерно-архітектурний інститут, Професійно-технічний університет будівництва Чжецзян Гуаньша, Дун'ян, Чжецзян, Китайська народна республіка, 322100, тел. +86-0579-86668872, ел. пошта 20191756@zjgsdx.edu.cn, ORCID 0009-0003-3417-8835

⁴Кафедра військової підготовки спеціалістів Державної спеціальної служби транспорту, Український державний університет науки і технологій, вул. Лазаряна, 2, Дніпро, Україна, 49010, тел. +38 (063) 191 14 09, ел. пошта b.y.bogdan@ust.edu.ua, ORCID 0009-0003-5845-9797

АНАЛІЗ ФОРМ І ЧАСТОТ ВЛАСНИХ КОЛИВАНЬ ТА ДИНАМІЧНИХ НАПРУЖЕНЬ ФУНДАМЕНТУ СТОЯНА МОСТУ І ГРУНТОВОЇ ОСНОВИ

Мета. Метою дослідницької роботи є визначення в ході модального аналізу форм і частот власних коливань стояна залізничного мосту разом із ростверком та пальовим фундаментом. Одним з завдань дослідження є з'ясування динамічного впливу конструкції стояна на можливість вібраційних переміщень ґрунтової основи. **Методика.** Для розрахунку пальового фундаменту стояна, який взаємодіє із оточуючим масивом, вирішено застосовувати метод скінченних елементів (FEM) на основі Structure CAD for Windows, version 7.31 R.4 (SCAD). Для відтворення особливостей пальового фундаменту стояна в роботі застосовано плоску (квазіпросторову) модель. Усі розміри ростверку та паль прийняті згідно проєктної документації спорудження реального шляхопроводу. **Результати.** Виконано аналіз результатів напружено-деформованого стану фундаментів стояна шляхопроводу із урахуванням поїзного навантаження, який надав змогу отримати висновок про високу несучу здатність усіх частин системи «палі – ростверк» на всі розглянуті види сполучень із запасом міцності в 8 і 7 разів відповідно, що свідчить про нормальну експлуатацію в подальшому при незмінному стані інженерно-геологічних умов і навантажень. Матеріал паль бетон класу С30/35 повністю витримує усі види навантажень, представлених сполученнями із урахуванням динамічного коефіцієнту. Проведений модальний аналіз фундаментів стояна шляхопроводу свідчить, що отримані частоти і форми фундаменту, які дорівнюють 2,5 Гц (основний тон)...6,6 Гц, а із порівняння цих частот з частотами розрідження вологих пісків (30...50 Гц) зрозуміло, що власні коливання опори не можуть викликати вібраційного розрідження. **Наукова новизна.** Наукова новизна проведених досліджень полягає в отриманні під час модального аналізу стояна залізничного мосту параметрів динамічних переміщень та частот власних коливань. **Практична значимість.** Практична значимість полягає в обґрунтуванні міцності конструкції стояна при варіації сполучень навантажень, а також у визначенні того, що динамічний вплив рухомого складу не впливає на вібраційні переміщення ґрунтів основи.

Ключові слова: фундамент стояна мосту; форми і частоти; власні коливання; динамічні напруження; ґрунтова основа

REFERENCES

- Ellis, E. A., & Springman, S. M. (2001). Modelling of soil–structure interaction for a piled bridge abutment in plane strain FEM analyses. *Computers and Geotechnics*, 28(2), 79-98. DOI: [https://doi.org/10.1016/S0266-352X\(00\)00025-2](https://doi.org/10.1016/S0266-352X(00)00025-2) (in English)
- Deng, Y., Ge, S., & Lei, F. (2023). Effects of pounding and abutment behavior on seismic response of multi-span bridge considering abutment-soil-foundation-structure interactions. *Buildings*, 13(1), 260. DOI: <https://doi.org/10.3390/buildings13010260> (in English)
- Dubinchyk, O., Bannikov, D., Kildieiev, V., & Kharchenko, V. (2020). Geotechnical analysis of optimal parameters for foundations interacting with loess area. *E3S Web of Conferences, II International Conference Essays of Mining Science and Practice*, 168, 00024. DOI: <https://doi.org/10.1051/e3sconf/202016800024> (in English)
- Li, Z. X., Zhou, T. Q., Chan, T. H. T., & Yu, Y. (2007). Multi-scale numerical analysis on dynamic response and local damage in long-span bridges. *Engineering Structures*, 29(7), 1507-1524. DOI: <https://doi.org/10.1016/j.engstruct.2006.08.004> (in English)
- Lu, P., Xie, X., & Shao, C. (2012). Experimental study and numerical analysis of a composite bridge structure. *Construction and Building Materials*, 30, 695-705. DOI: <https://doi.org/10.1016/j.conbuildmat.2011.11.008> (in English)
- Rashidi, M., Zhang, C., Ghodrati, M., Kempton, S., Samali, B., Akbarnezhad, A., & Zhu, L. (2018). Bridge abutment movement and approach settlement – A case study and scenario analysis. *International Journal of Structural Stability and Dynamics*, 18(08), 1840011. DOI: <https://doi.org/10.1142/S0219455418400114> (in English)
- Stewart, D. P., Jewell, R. J., & Randolph, M. F. (1993). Numerical modelling of piled bridge abutments on soft ground. *Computers and Geotechnics*, 15(1), 21-46. DOI: [https://doi.org/10.1016/0266-352X\(93\)90015-Y](https://doi.org/10.1016/0266-352X(93)90015-Y) (in English)
- Whelan, M. J., Gangone, M. V., Janoyan, K. D., & Jha, R. (2009). Real-time wireless vibration monitoring for operational modal analysis of an integral abutment highway bridge. *Engineering Structures*, 31(10), 2224-2235. DOI: <https://doi.org/10.1016/j.engstruct.2009.03.022> (in English)
- Wu, L., Jiang, G., & Liu, X. (2020). Analytical and Numerical Analysis of Additional Stress in Foundation of Bridge Approach Embankment. *Geotechnical and Geological Engineering*, 38, 6069-6082. DOI: <https://doi.org/10.1007/s10706-020-01414-2> (in English)
- Wymysłowski, M., & Kurałowicz, Z. (2016). Study of displacements of a bridge abutment using FEM. *Studia Geotechnica et Mechanica*, 38(2), 61-70. DOI: <https://doi.org/10.1515/sgem-2016-0020> (in English)
- Dubinchyk, O. I., & Neduzha, L. O. (2021). Obgruntuvannya napruzhenno-deformovanoho stanu palovoho fundamentu z vykorystanniam prohramnykh kompleksiv. *Mosty ta tuneli: teoriia, doslidzhennia, praktyka*, 20, 13-18. DOI: <https://doi.org/10.15802/bttrp2021/245247> (in Ukrainian)
- DBN V.2.1-10-2009 (2009). *Osnovy ta fundamenty sporud. Osnovni polozhennia proiektuvannia*. Kyiv: Minre-hionbud Ukrainy. (in Ukrainian)
- DBN V.1.2-2:2006 (2006). *Navantazhennia i vplyvy. Normy proektuvannia*. Kyiv: Minbud Ukrainy. (in Ukrainian)
- Karpilovskiy, V. S., Kriksunov, E. Z., Perelmuter, A. V., & al. (2000). *SCAD dlya polzovatelya*. Kiev: VVP «Kompas». (in Russian)

Надійшла до редколегії 18.04.2025.

Прийнята до друку 22.05.2025.